

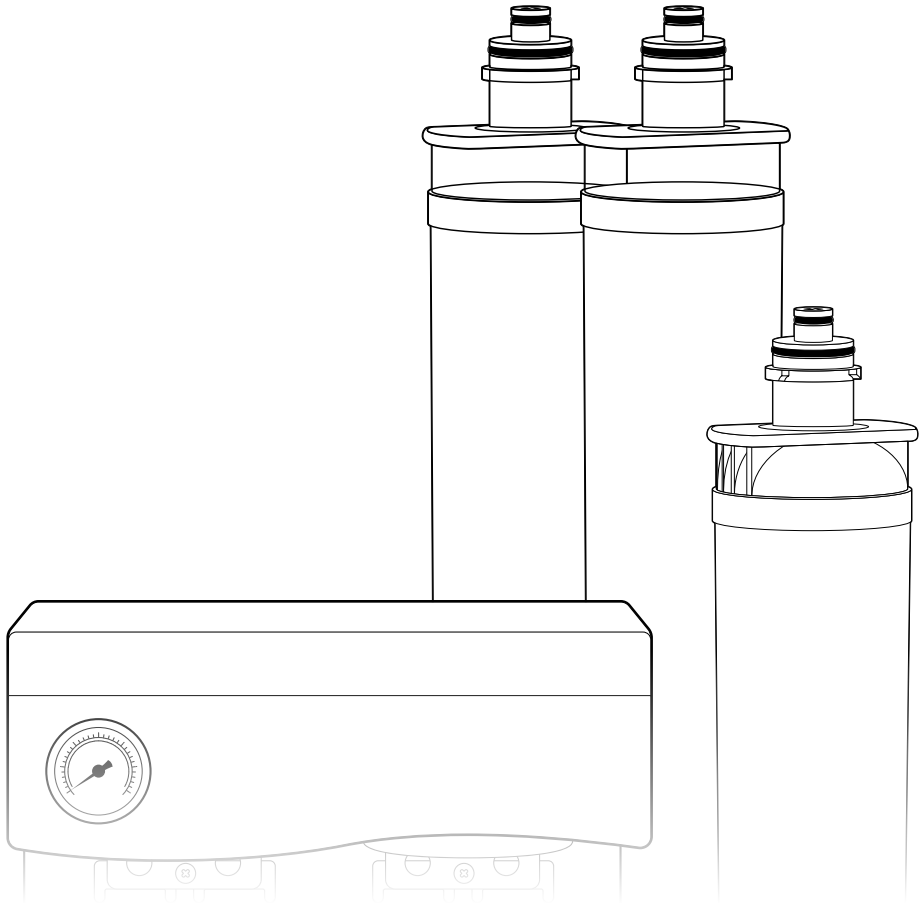

# CO Series

*Food Service Filtration Product Range User Guide*



## What's Inside

Introduction.....	2
Operation.....	2
Cartridge Selection.....	3
Cartridge Replacement.....	4
Installation.....	4
Installation Procedure .....	4
Cartridge Changeout.....	9
Use Guidelines.....	9
Warranty.....	10

## Puretec Customer Service

Thank you for purchasing a Puretec Food Service Filtration System. Your system is a proven performer, manufactured from only quality materials and components, if maintained properly it will provide years of quality water.

Cartridges for this system need replacing regularly to maintain optimum performance. This is a simple procedure when following instructions. For cartridge replacements contact your nearest Puretec stockist.

Customer Service Helpline **1300 140 140** (Australia) **0800 130 140** (New Zealand).

## Operation

This Puretec Food Service Filtration System is designed to help your commercial catering equipment work at peak performance. Flush systems as per cartridge instructions. Puretec Food Service Filtration Systems are designed to operate with mains water only.



**WaterMark**

AS 3497

Licence No. WM 74617

Pro-Switch Pty Ltd

## Cartridge Selection

Puretec Model:	Description	Application
CO-I50, CO-350, CO-250	Hardness, Taste & Odour Reduction and pH Balance	Coffee, Tea, Steam and Warewashing
CO-B150, CO-B200	Taste & Odour Reduction with Unique Scale Prevention and Mineral Retention	Coffee
CO-S150	High Capacity Sediment Reduction	Ice
CO-T100, CO-T150, CO-T200	Hardness, Taste & Odour Reduction	Coffee, Tea, Beverages, Post Mix and Ice
CO-UZ150	Taste & Odour Removal with Scale Inhibitor	Ice, Tea, Beverages, Post Mix
CO-I150, CO-I250, CO-I350	Interblend for Hardness, Taste & Odour Reduction and pH Balance	Post Mix, Coffee, Tea Beverages, Hot Water Dispensers, Steam, Ice
CO-VI250	Interblend with Variable Bypass, Hardness, Taste & Odour Reduction and pH Balance	Post Mix, Coffee, Tea Beverages, Hot Water Dispensers, Steam, Ice
CO-R200	pH Boost with Mg+ Technology, removes sediment, bad taste & odour, Balances Water and Restores Essential Minerals	Coffee, Tea, Beverages
CO-THF150	High Flow Chlorine, Taste & Odour Cartridge with Scale Inhibitor	Coffee, Tea, Beverages
N/A	Quick-Twist Systems - Inline and Parallel	Coffee

## Cartridge Replacement

To maintain the high quality of the purified water the cartridges need changing every 6 months (this is dependant on water quality and usage).

You can obtain replacement cartridges from your local Puretec dealer. To maintain performance standards and warranty, use only genuine Puretec replacements.

Refer to your cartridge for replacement model number.

## Installation

This system comes complete with an installation kit enabling it to be connected to 10mm ( $\frac{3}{8}$ " ) male thread or tubing to an existing appliance (Cold supply only - hot water should be filtered prior to heating).

## Installation requirements

1. 10mm ( $\frac{3}{8}$ " ) Cold water flexi-connector or tubing.
2. Water supply pressure: Refer to cartridge.
3. Water supply temperature: Refer to cartridge.

Alternative fittings may be required if being connected to anything other than 10mm ( $\frac{3}{8}$ " ) male thread or tubing. No electrical or drainage requirements needed.

**Note:** For point of entry installations an approved dual check backflow prevention device must be installed.

## Installation Procedure

1. Place container under filter in case of drips (if applicable).
2. Isolate water supply and release water pressure by operating appliance. Disconnect/ remove any existing filters (if applicable).
3. Position head to the desired location (mount).
4. Connect original fittings onto the head assembly outlet. Make sure all fittings are tight and braided hose or tube are kink free.
5. Install cartridge to the head assembly (see pages 5-7). Please note arrow on cartridge.
6. Restore the water supply and check for leaks. If they leak then undo cartridge and check the cartridge is seated properly.
7. Flush the system for at least 5 minutes (operate appliance to run cold water) to remove carbon fines. Water may appear milky or soapy but this is normal and is only tiny air bubbles that will clear after a short period.

## 2-Stage Manifold Assembly

After mounting the manifold the cartridges for the system will need to be installed. For the correct cartridge installation order see the table below:

Replacement Parts:	Stage 1 Cartridge* (Left)	Stage 2 Cartridge (Right)
<b>CO-UB150-K</b>	CO-UZ150	CO-B150
<b>CO-UB200-K</b>	CO-UZ150	CO-B200
<b>CO-SB150-K</b>	CO-S150	CO-B150
<b>CO-SB200-K</b>	CO-S150	CO-B200
<b>CO-ST100-K</b>	CO-S150	CO-T100
<b>CO-ST150-K</b>	CO-S150	CO-T150
<b>CO-ST200-K</b>	CO-S150	CO-T200
<b>CO-SZ150-K</b>	CO-S150	CO-UZ150

*\*Stage 1 Cartridge is nearest to the water inlet.*

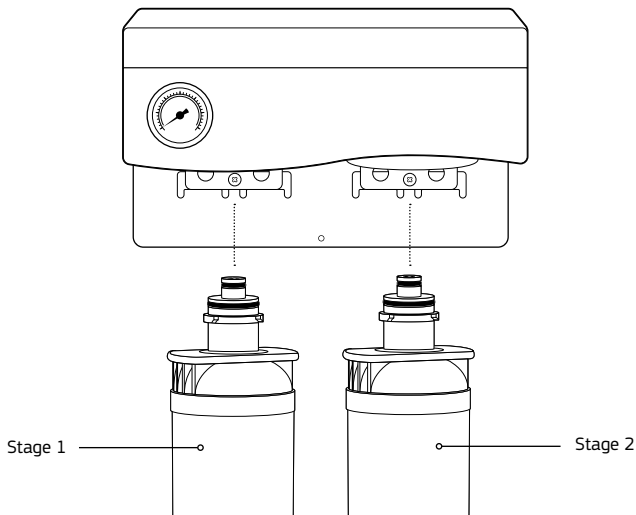

## 3-Stage Manifold Assembly

After mounting the manifold, the cartridges for the system will need to be installed. For the correct cartridge installation order see the table below:

Replacement Parts:	Stage 1 Cartridge* (Left)	Stage 2 Cartridge (Middle)	Stage 3 Cartridge (Right)
<b>CO-SUB150-K</b>	<b>CO-S150</b>	<b>CO-UZ150</b>	<b>CO-B150</b>
<b>CO-SUB200-K</b>	<b>CP-S150</b>	<b>CO-UZ150</b>	<b>CO-B200</b>

*\*Stage 1 Cartridge is nearest to the water inlet.*

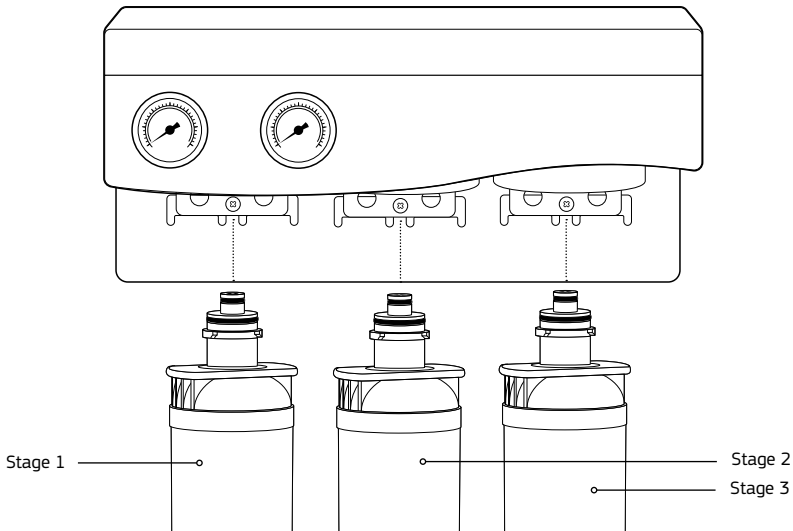

## CO-S3T150-K Assembly

After mounting the pre-filter housing & manifold, the cartridges for the system will need to be installed. For the correct cartridge installation order see the diagram below:

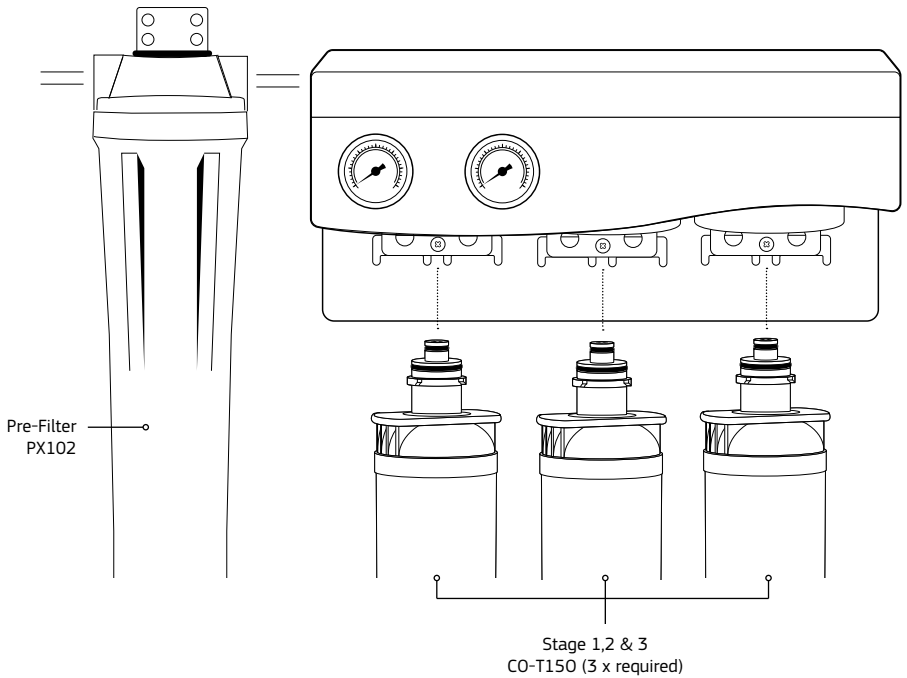

## Filter Assemblies

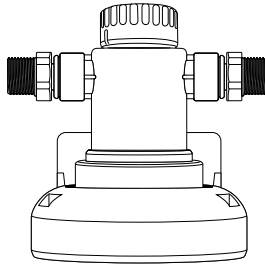
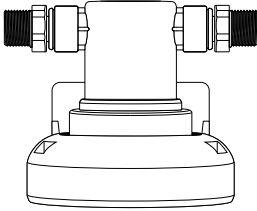

Replacement Parts:

**FILTER HEAD**

**CO-HEAD**

**FILTER HEAD WITH VARIABLE BYPASS**

**CO-VIHEAD**

## CO-M Manifold Assemblies

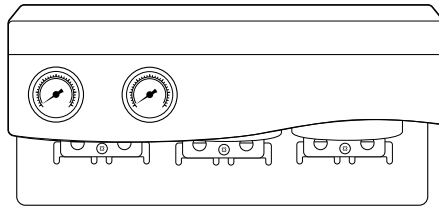
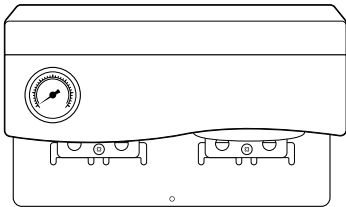

Replacement Parts:

Parallel

Series

**2-STAGE**

**CO-M2P**

**CO-M2S**

**3-STAGE**

**CO-M3P**

**CO-M3S**



## Cartridge Changeout

1. Place container under filter in case of drips.
2. Unscrew cartridge in a clock-wise direction. Discard old cartridge.

**Note:** Filter heads have a built in shut off valve to eliminate the need to shut off the water supply.

3. Take off safety cap from the new cartridge. Twist new cartridge into head until firmly seated. Please note arrow on cartridge to indicate this.
4. Restore water supply.
5. Check for any leaks, rectify them if any, before leaving the unit.
6. After installing cartridge flush unit for 5 minutes or until clear.

## Use Guidelines

- Use for mains water only.
- For minimum operating pressure, refer to cartridge.
- For maximum operating pressure, refer to cartridge.
- For minimum operating temperature, refer to cartridge.
- For maximum operating temperature, refer to cartridge.
- For flow rate, refer to cartridge.
- All systems must be installed according to local plumbing codes on the cold water line only.
- Replacement Cartridges: See Cartridge Selection Guide.
- This system requires regular replacement of the filter cartridge to maintain proper operation. Varying chlorine, sediment, or organic substance levels may affect filter capacity.
- Be sure to change the filter cartridge at least every 6 months, or whenever you detect a change in taste, odour, or decrease in flow.

Caution: Do not use with water that is microbiologically unsafe or of unknown quality without adequate disinfection before or after the system.

## Notes

Puretec water care products are designed, manufactured and supported by Puretec Pty Ltd the name you can trust for viable and proven water solutions. The complete range of Puretec products are developed, refined, made to meet and exceed stringent specifications for the worldwide market.

Important: Sales of products are subject to our Terms and Conditions which are available upon request. All specifications, information and photos are a guide only and are subject to change without notice. Please ring to confirm details. Warning: For correct operation of this appliance it is essential to observe manufacturer's instructions.

All installation and service work should be completed by qualified tradespeople. Faulty operation due to unqualified persons will result in voided warranty coverage.

## Warranty

Any claim under this warranty must be made within 3 Years of the date of purchase of the product. This product is warranted to be free of defect of material and workmanship for 3 Years from date of purchase. Warranty is 1 year parts and labour plus 2 years parts only, excludes cartridges.

Puretec is renowned for its quality and after-sales support so if you have any issues please call 1300 140 140 (AU) or 0800 130 140 (NZ). To make a warranty claim, contact us directly or the place of original purchase. All costs relating to a warranty claim must be approved by Puretec prior to any work being carried out.

Puretec will pay your reasonable, direct expenses of claiming under this warranty. You may submit details and proof of your expense claim to place of purchase for consideration.

The warranty only applies if the product was used and/or installed in accordance with the user guide and/or installation instructions. This warranty is given in lieu of all other express or implied warranties and manufacturer shall in no circumstance be held liable for damages consequential or otherwise or delays caused or faulty manufacturing except as excluded by law.

## **Warranty/Australia**

This warranty is given by Puretec Pty Ltd, ABN 44 164 806 688, 37-43 Brodie Road, Lonsdale SA 5160, telephone no. 1300 140 140 and email at sales@puretec.com.au.

This warranty is provided in addition to other rights and remedies you have under law: Our goods come with guarantees which cannot be excluded under the Australian Consumer Law. You are entitled to replacement or refund for a major failure and to compensation for other reasonably foreseeable loss or damage. You are also entitled to have the goods repaired or replaced if the goods fail to be of acceptable quality and the failure does not amount to a major failure.

## **Warranty/New Zealand**

This warranty is given by Puretec NZ LP, Reg. No 50081773, PO Box 13116, Hillcrest, Hamilton 3251 NZ, telephone no. 0800 130 140 and email at sales@puretec.co.nz.

This warranty is provided in addition to other rights and remedies you have under law: Our goods come with guarantees which cannot be excluded under the Consumer Guarantees Act. You are entitled to replacement or refund for a major failure and to compensation for other reasonably foreseeable loss or damage. You are also entitled to have the goods repaired or replaced if the goods fail to be of acceptable quality and the failure does not amount to a major failure.



JUL2024 UG-FS

**Australia**

**P 1300 140 140**

**E [sales@puretecgroup.com](mailto:sales@puretecgroup.com)**

**W [puretec.com.au](http://puretec.com.au)**

**New Zealand**

**P 0800 130 140**

**E [sales@puretecgroup.com](mailto:sales@puretecgroup.com)**

**W [puretec.co.nz](http://puretec.co.nz)**